

User Manual

Legacy Multiswitches

MSW504 - MSW508 - MSW512 - MSW516 - MSW524 - MSW532
 MSW908 - MSW912 - MSW916 - MSW924 - MSW932
 MSW1308 - MSW1312 - MSW1316 - MSW1324 - MSW1332
 MSW1708 - MSW1712 - MSW1716 - MSW1724 - MSW1732

Multiswitch Amplifiers

MSWA5 - MSWA9 - MSWA13 - MSWA17

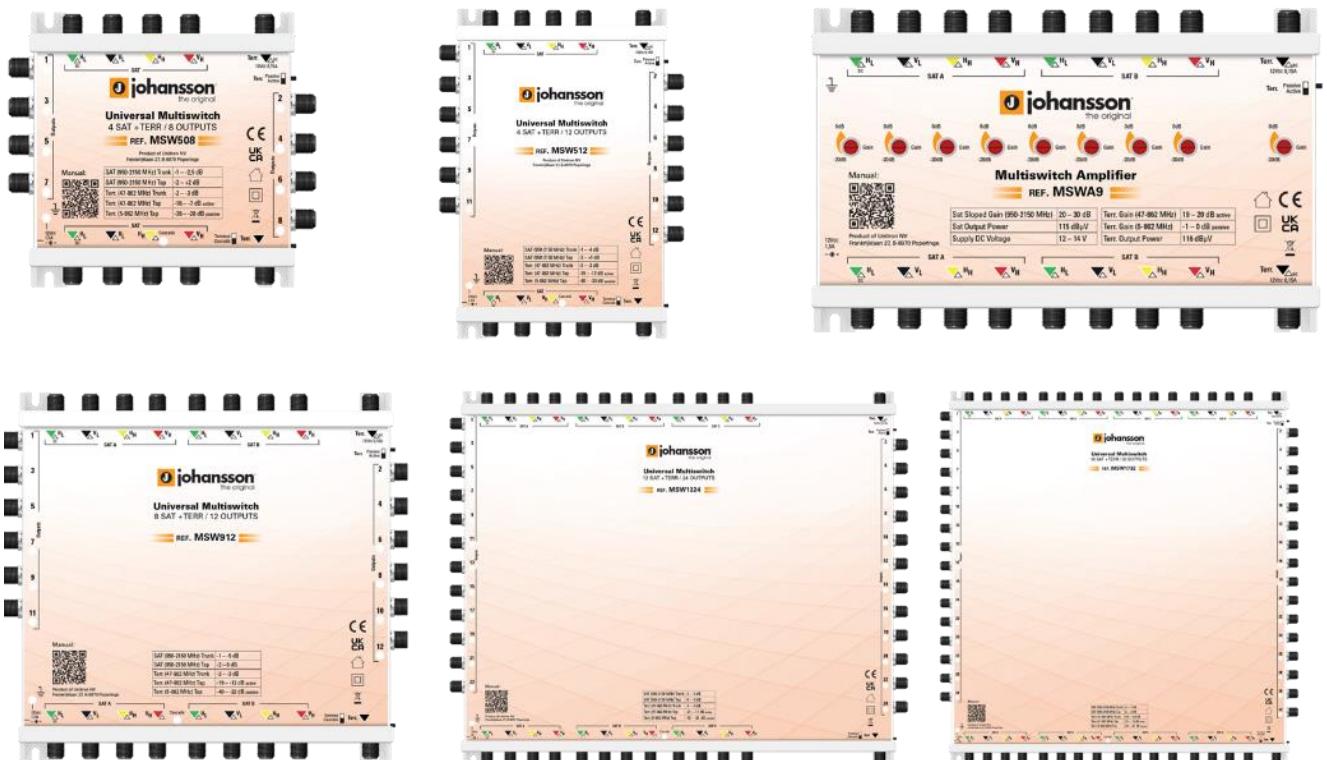

CONTENTS

1. PRODUCT DESCRIPTION	3
2. TECHNICAL SPECIFICATIONS	4
2.1. Multiswitch Specs	4
2.2. Multiswitch Amplifier Specs	8
3. INSTALLATION OF THE HARDWARE	9
4. INSTALLATION EXAMPLES.....	11
4.1. 1 SAT Position	11
4.1. 2 SAT Positions.....	12
4.1. 3 SAT Positions.....	13
4.1. 4 SAT Positions.....	14
5. SAFETY INSTRUCTIONS	15
6. CONDITIONS OF WARRANTY.....	16

No part of this manual may be copied, reproduced, transmitted, transcribed or translated into any language without permission.

Unitron reserves the right to change the specifications of the hardware and software described in these manuals at any time.

Unitron cannot be held liable for any damages resulting from the use of this product. Specifications are subject to change without notice. 9/25

© Unitron NV - Frankrijklaan 27 - B-8970 Poperinge - Belgium

T +32 57 33 33 63

sales@unitrongroup.com

www.unitrongroup.com

1. PRODUCT DESCRIPTION

Welcome to the Johansson Legacy Series – a full range of high-quality multiswitches and amplifiers designed for professional satellite and terrestrial TV distribution. Whether you're working on residential, commercial, or large-scale installations, our products deliver exceptional performance, flexibility, and reliability.

Key Features:

- Compatible with **5-wire, 9-wire, 13-wire, and 17-wire** systems
- Available with **4 to 32 outputs** to fit any installation size
- **Standalone or cascadable**, easily configurable via switch
- **Active or passive terrestrial path**, switch-selectable
- Patented **transistor switching design** for excellent signal quality, even at low input levels
- **12V 0.15A terrestrial feeding** for enhanced performance
- **LED indicators** at taps for quick troubleshooting
- **Compact design**, A-class, CE-approved
- **DiSEqC 2.0 compatible** for seamless receiver integration
- **External SMPS power supply** for stable and efficient operation

Multiswitch Amplifiers (30 dB Adjustable Gain):

MSWA5 – MSWA9 – MSWA13 – MSWA17

Power Supply - PSU1236(UK):– 12V / 3.0A Power Supply with EU or UK mains cable.

Our range of multiswitches and amplifiers ensures seamless satellite and terrestrial distribution with **high efficiency, low noise, and maximum reliability**. Whether you're expanding an existing system or setting up a new installation, Johansson Legacy products provide the flexibility and performance you need.

2. TECHNICAL SPECIFICATIONS

2.1. Multiswitch Specs

4SAT + 1 Terr Inputs

		MSW504	MSW508	MSW512	MSW516	MSW524	MSW532
Inputs	SAT polarities + Terr	4IF+1Terr					
Tap Number		4	8	12	16	24	32
Trunk Loss (dB)	SAT 950...2150MHz	-1...-2,5		-1...-4		-2...-5	-2...-7
Tap Loss (dB)		-2...+2		-3...+1		-4...0	-4...-1
Trunk Loss (dB)	Terr 47...862MHz	-3...-4	-2...-3				-2,5...-3,5
Tap Loss (dB) Active		-7...0	-16...-7	-19...-12		-20...-11	-21...-13
Tap Loss (dB) Passive	Terr 5...862MHz	-27...-20	-38...-28	-40...-33		-42...-35	-43...-38
Isolation	H/V	>30dB					
Return Loss	Terr 47...862MHz	>10dB					
	SAT 950...2150MHz						
Output level (IMD3, EN50083-5)	SAT	100 dB μ V					
	Terr	92 dB μ V					
LNB Power Supply		12 Vdc / 250 mA max per input					
Consumption in Terr Active Mode		130 mA					
Consumption from the Receiver		40 mA					
Switching commands		DiSEqC 2.0 / 13V, 18V, 13V+22KHz, 18V+22KHz					
Dimensions LxWxH (cm)		8x13x4	11x13x4	17x13x4		23x13x4	30x13x4

8 SAT + 1 Terr Inputs

		MSW908	MSW912	MSW916	MSW924	MSW932
Inputs	SAT polarities + Terr	8IF+1Terr				
Tap Number		8	12	16	24	32
Trunk Loss (dB)	SAT 950...2150MHz	-1...-2,5	-1...-5		-2...-5	-2...-7
Tap Loss (dB)		-2...+2	-2...0		-3...0	-3...-1
Trunk Loss (dB)	Terr 47...862MHz	-2...-3				-2,5...-3,5
Tap Loss (dB) Active		-16...-7	-19...-12		-20...-11	-21...-13
Tap Loss (dB) Passive	Terr 5...862MHz	-38...-28	-40...-33		-42...-35	-43...-38
Isolation	H/V	>30dB				
Return Loss	Terr 47...862MHz	>10dB				
	SAT 950...2150MHz					
Output level (IMD3, EN50083-5)	SAT	100 dB μ V				
	Terr	92 dB μ V				
LNB Power Supply		12 Vdc / 250 mA max per input				
Consumption in Terr Active Mode		130 mA				
Consumption from the Receiver		40 mA				
Switching commands		DiSEqC 2.0 / 13V, 18V, 13V+22KHz, 18V+22KHz				
Dimensions LxWxH (cm)		11x13x4	17x19x4		23x19x4	30x19x4

12 SAT + 1 Terr Inputs

		MSW1308	MSW1312	MSW1316	MSW1324	MSW1332
Inputs	SAT polarities + Terr	12IF+1Terr				
Tap Number		8	12	16	24	32
Tap Loss (dB)	SAT 950...2150MHz	-1...+2	-2...+1	-2...0		-2...-1
Tap Loss (dB) Active	Terr 47...862MHz	-1...+1	-1...+1	-1...0		-2...-1
Tap Loss (dB) Passive	Terr 5...862MHz	-21...-19	-21...-19	-19...-20		-22...-21
Isolation	Terr to SAT	>24dB				
	SAT to Terr	>30dB				
	Cross polar. H/V	>35dB				
Isolation Between Users	Terr to Terr	>30dB				
	Sat to Sat	>30dB				
Return Loss	Terr 47...862MHz	>10dB				
	SAT 950...2150MHz	>10dB				
Output level (IMD3, EN50083-5)	SAT	100 dB μ V				
	Terr	92 dB μ V				
LNB Power Supply		12 Vdc / 250 mA max per input				
Consumption in Terr Active Mode		130 mA				
Consumption from the Receiver		50 mA				
Switching commands		DiSEqC 2.0 / 13V, 18V, 13V+22KHz, 18V+22KHz				
Dimensions LxWxH (cm)		12x31x4	19x31x4	26x31x4	31x31x4	

16 SAT + 1 Terr Inputs

		MSW1708	MSW1712	MSW1716	MSW1724	MSW1732
Inputs	SAT polarities + Terr	16IF+1Terr				
Tap Number		8	12	16	24	32
Trunk Loss (dB)	SAT 950...2150MHz	-1...-3	-1...-5		-2...-5	-2...-7
Tap Loss (dB)		-4...-2	-5...-3		-6...-3	-6...-4
Trunk Loss (dB)	Terr 47...862MHz	-2...-3				-2,5...-3,5
Tap Loss (dB) Active		-27...-5	-19...-8		-21...-11	-21...-12
Tap Loss (dB) Passive	Terr 5...862MHz	-38...-26	-40...-29		-42...-32	-43...-33
Isolation	H/V	>30 dB				
Return Loss	Terr 47...862MHz	>10dB				
	SAT 950...2150MHz					
Output level	SAT (IMD3, EN50083-5)	100 dB μ V				
	Terr (IMD3, EN50083-5)	92 dB μ V				
LNB Power Supply		12 Vdc / 250 mA max per input				
Consumption in Terr Active Mode		130 mA				
Consumption from the Receiver		40 mA				
Switching commands		DiSEqC 2.0 / 13V, 18V, 13V+22KHz, 18V+22KHz				
Dimensions LxWxH (cm)		12x31x4	19x31x4		26x31x4	31x31x4

2.2. Multiswitch Amplifier Specs

Model		MSWA5	MSWA9	MSWA13	MSWA17
Inputs and outputs	SAT polarities+Terr	4IF+1Terr	8IF+1Terr	12IF+1Terr	16IF+1Terr
Gain (dB)	SAT 950...2150MHz	22...29			
	active Terr 47...862MHz	19...20			
	passive Terr 5...862MHz	-1...-2			
Gain adjustment (dB)	SAT 950...2150MHz	20			
	Terr 5...862MHz				
Output power (dBμV) (IMD3, EN50083-5)	SAT	112			
	active Terr	110			
	passive Terr	-			
Return loss (dB)	SAT 950...2150MHz	>10			
	active Terr 47...862MHz				
	passive Terr 5...862MHz				
Operating voltage (V)		12			
Current consumption (A)		1,2		2,1	
Dimensions	LxWxH (cm)	17x11,5x4		28,5x12x4	

3. INSTALLATION OF THE HARDWARE



CAUTION: for proper operation of the device, mount the Multiswitch vertically to a wall in a well-ventilated room, leave a minimum space of 15cm around the device

1. Connect the satellite trunk cables to the Multiswitch

- The satellite inputs are intended for satellite signals: 950 to 2150 MHz.

2. Connect the terrestrial cable to the module

- Depending on the application, an additional LTE blocking filter may be required.

3. Select to enable or disable the terrestrial amplifier (A.)

- In active mode, the gain of the amplifier is 20dB

4. Connect the receiver cables to the Multiswitch

- Each output has a LED indicator

5. Set the Terminal/Cascade switch according to the system (B.). Setting the switch to Terminal, the outputs will block....,

6. Connect the trunk outputs of the multiswitch to the next multiswitch (cascadable)

7. Use a Multiswitch Amplifier to enhance the signal quality of the system.

8. Connect an earth wire to the ground the device1/system

9. Power the device/system with 12 Vdc (C.)

- One ref. PSU1236 can power one installation
- Next page explains DC-powering more in-depth

Powering schematics

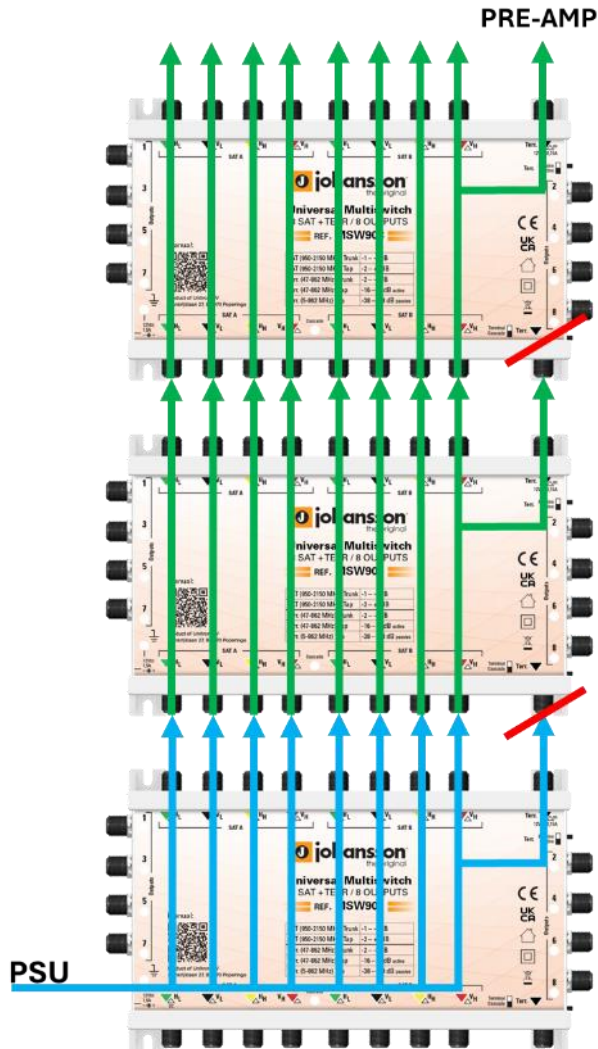

4. INSTALLATION EXAMPLES

4.1. 1 SAT Position

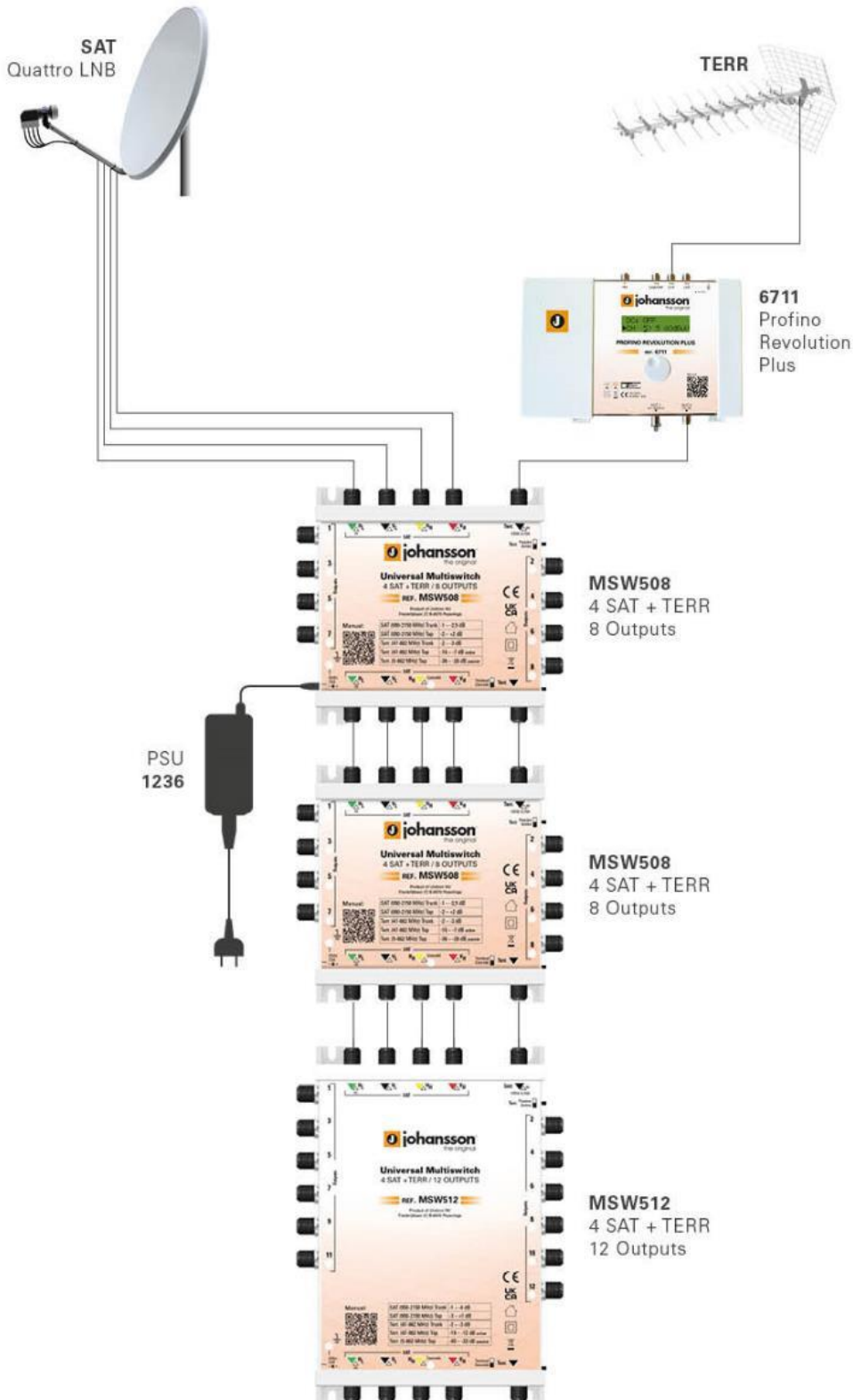

4.1. 2 SAT Positions

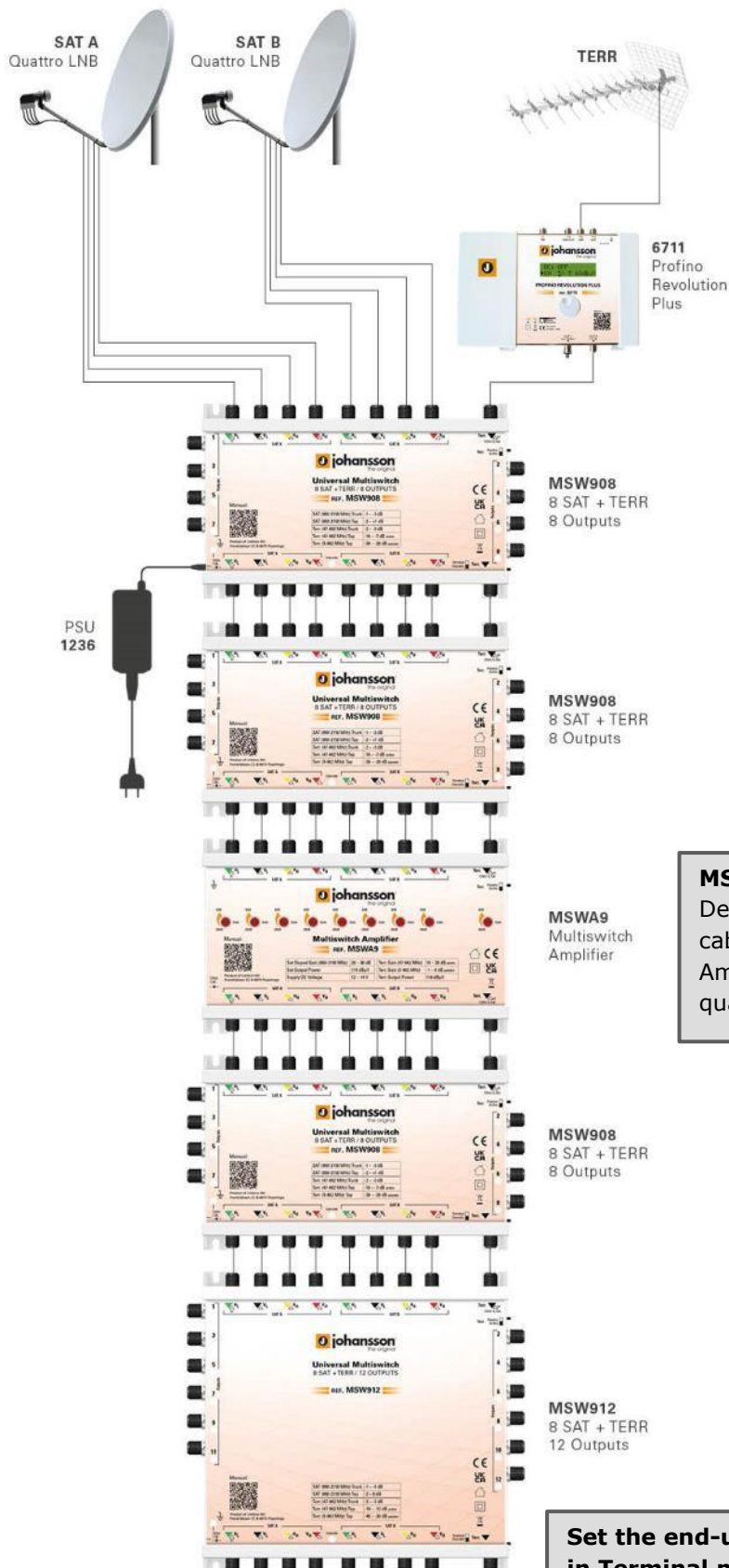

4.1. 3 SAT Positions

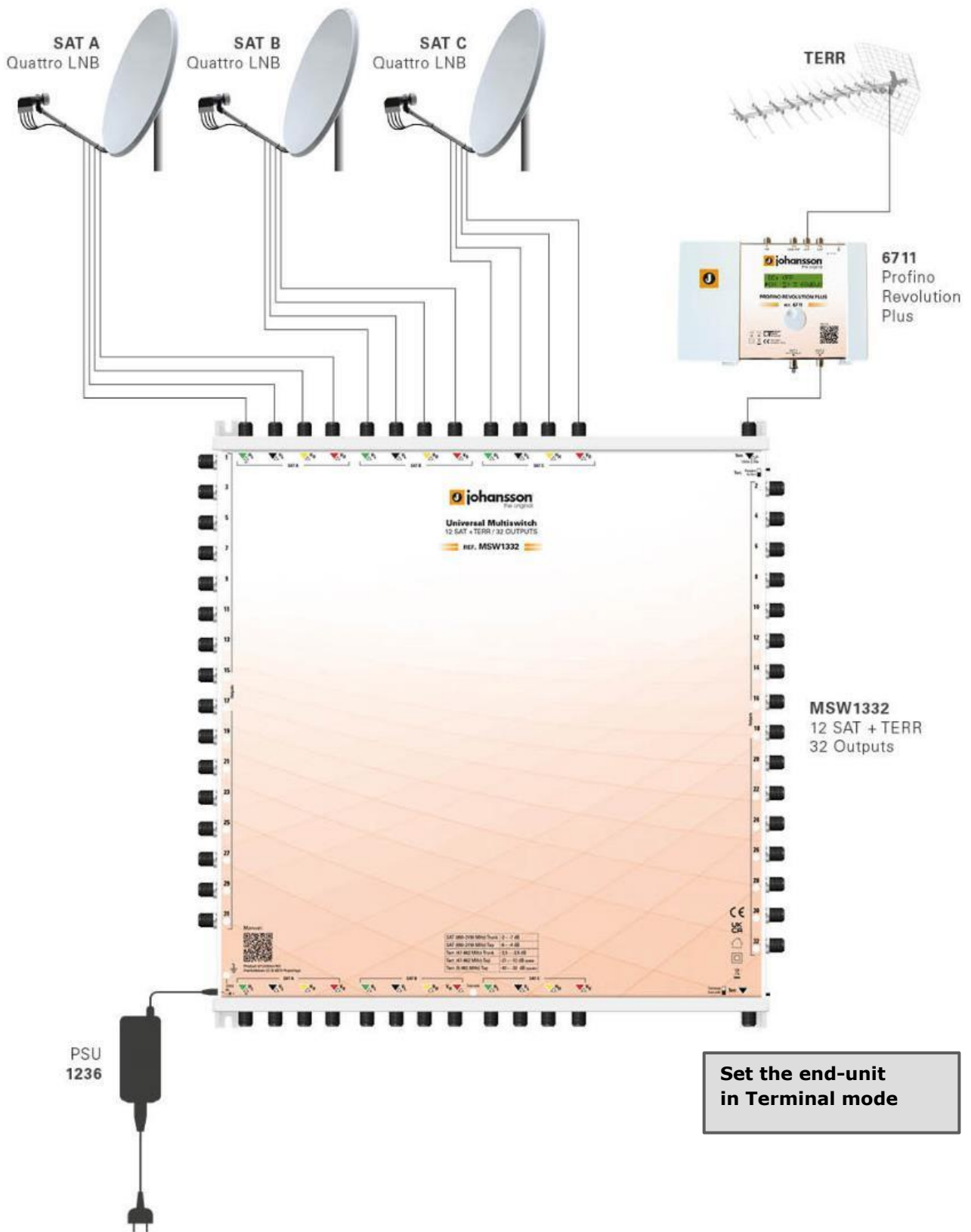

4.1. 4 SAT Positions

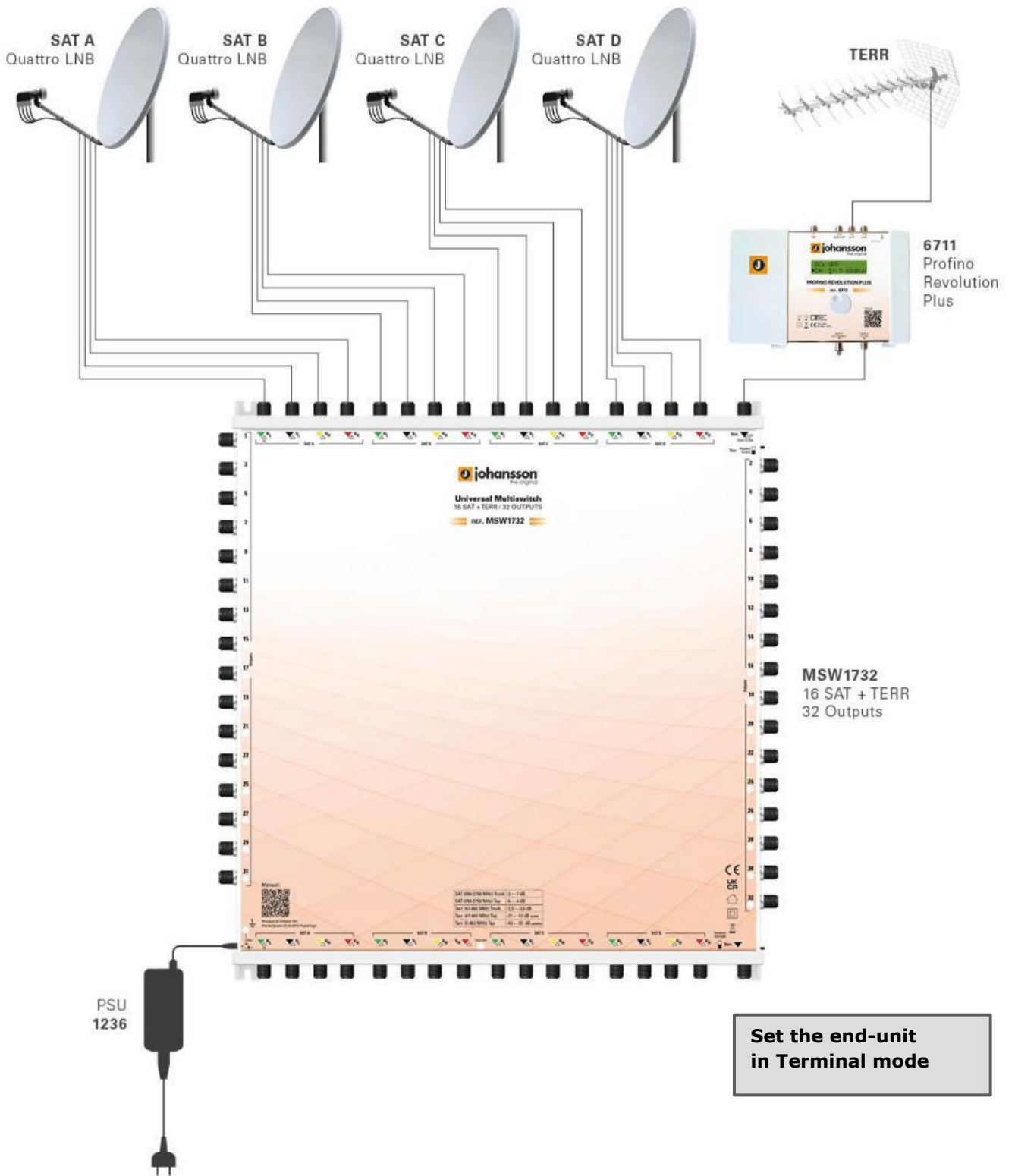

5. SAFETY INSTRUCTIONS



Read these instructions carefully before connecting the unit



To prevent fire, short circuit or shock hazard:

- Do not expose the unit to rain or moisture.
- Install the unit in a dry location without infiltration or condensation of water.
- Do not expose it to dripping or splashing.
- Do not place objects filled with liquids, such as vases, on the apparatus.
- If any liquid should accidentally fall into the cabinet, disconnect the power plug.



To avoid any risk of overheating:

- Install the unit in a well aery location and keep a minimum distance of 15 cm around the apparatus for sufficient ventilation
- Do not place any items such as newspapers, table-cloths, curtains, on the unit that might cover the ventilation holes.
- Do not place any naked flame sources, such as lighted candles, on the apparatus
- Do not install the product in a dusty place
- Use the apparatus only in moderate climates (not in tropical climates)
- Respect the minimum and maximum temperature specifications



To avoid any risk of electrical shocks:

- Connect apparatus only to socket with protective earth connection.
- The mains plug shall remain readily operable
- Pull out power plug to make the different connections of cables
- To avoid electrical shock, do not open the housing of adapter.



Maintenance



Only use a dry soft cloth to clean the cabinet.



Do not use solvent



For repairing and servicing refer to qualified personnel.



Dispose according your local authority's recycling processes

6. CONDITIONS OF WARRANTY

Unitron N.V. warrants the product as being free from defects in material and workmanship for a period of 24 months starting from the date of production indicated on it. See note below.

If during this period of warranty the product proves defective, under normal use, due to defective materials or workmanship, Unitron N.V, at its sole option, will repair or replace the product. Return the product to your local dealer for reparation.

THE WARRANTY IS APPLIED ONLY FOR DEFECTS IN MATERIAL AND WORKMANSHIP AND DOES NOT COVER DAMAGE RESULTING FROM:

- Misuse or use of the product out of its specifications,
- Installation or use in a manner inconsistent with the technical or safety standards in force in the country where the product is used,
- Use of non-suitable accessories (power supply, adapters...),
- Installation in a defect system,
- External cause beyond the control of Unitron N.V. such as drop, accidents, lightning, water, fire, improper ventilation...

THE WARRANTY IS NOT APPLIED IF

- Production date or serial number on the product is illegible, altered, deleted or removed.
- The product has been opened or repaired by a non-authorized person.

NOTE

Date of production can be found in the product's serial number code. The format will either be "YEAR W WEEK" (e.g., 2017W32 = year 2017 week 32) or "YYWW" (e.g., 1732 = year 2017 week 32).



www.unitrongroup.com

UNITRON NV
Frankrijklaan 27
B-8970 Poperinge
Belgium

T +32 57 33 33 63

sales@unitrongroup.com

www.unitrongroup.com